

New method for marking unique identification

Background

In order to raise the quality and to rationalise the marking of unique ID numbers on our rotators, we are introducing mechanical embossing of the numbers on rotator models wherever it is technically possible to do so. The unique ID number is the safest way of identifying the exact rotator model. This is especially important when ordering spare parts and for customer service identification.

Models concerned:

- AV 12, AV 14, AV 17
- GV 12, GV 14, GV 17, GV 124
- G121, G141, G171,
- H121, H122, H132, H172

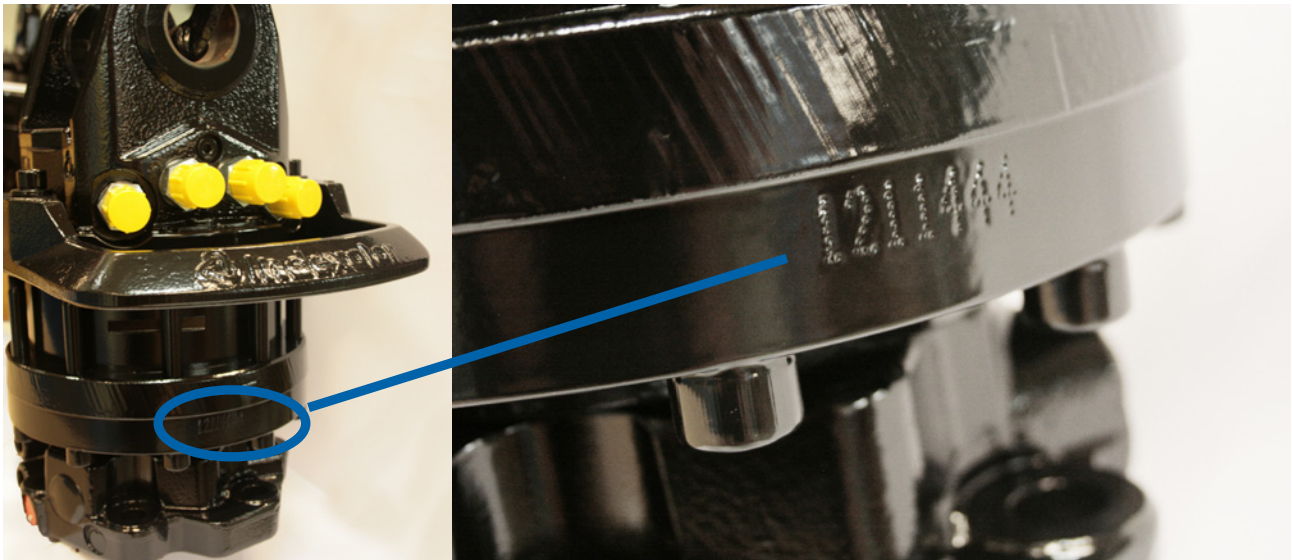

The ID marking is positioned on the processed section of the lower stator, below any hose and hydraulic connection shielding.



Positioning of unique ID numbers for all rotator models

All rotator models are also identifiable with a sticker on the upper stator. This sticker displays information about the ID number, with bar coding and printed figures. The positioning on the upper stator is to facilitate identification as the rotators stand together on the same pallet.

Positioning of ID numbers

GV 3



GV 4

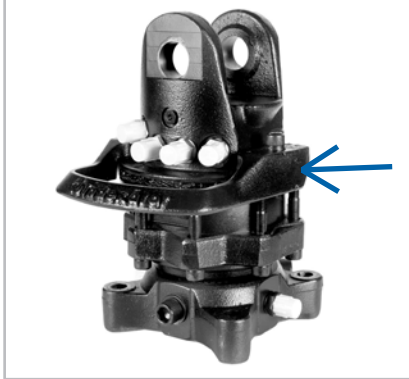

GV 6

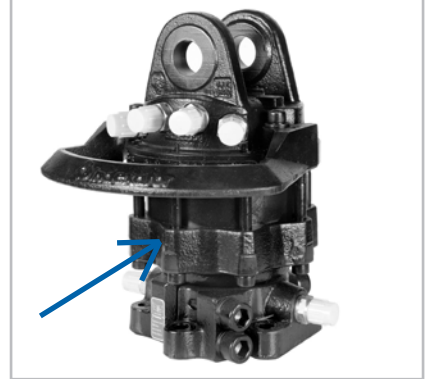

AV 12/14/17
H 12/13/17



GV 12/14/17
G 12/17

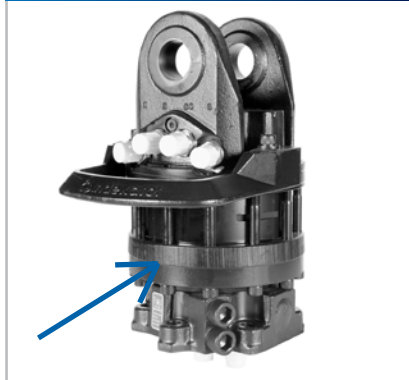

GV 124



IR 10/20
IR 12/22



IR 25



SR 18/21

